

# CENTRALIZED LUBRICATION SYSTEMS



**ADVANCED FLUID  
MANAGEMENT SOLUTIONS**

**GENERAL  
CATALOG No.**

**803**



**15**



**20**



**25**



**30**





## HELP THE NATURE

Packaging contains, depending on the articles, one or more of the following materials; they must be recycled in accordance with current regulations in the country of use.

cardboard • polyethylene sack • polystyrene  
paper • wood • nails • plastic strap  
cellophane • clips • gummed paper

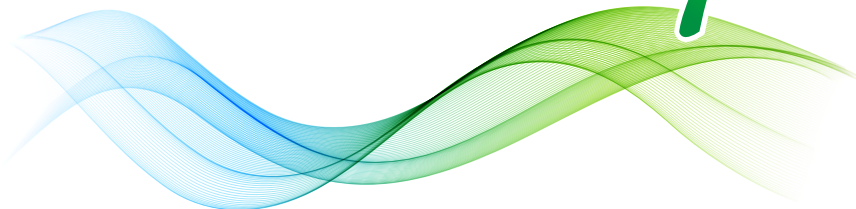



**ADVANCED FLUID  
MANAGEMENT SOLUTIONS**



DESIGN IS AN

*Art*





founded in 1975



*the human side  
of Quality*



# STUDY, RESEARCH AND DESIGN

The real strength of a firm starts with the ability of its study and research departments to always find the most suitable solutions to address market demands.



# TESTING AND INSPECTIONS

A sophisticated test room enables careful testing of the quality of new products before they are put on the market.

# ASSEMBLY LINES

Dedicated equipment specially designed to facilitate assembly operations, at the same time allowing an effective and automatic control of quality.



# STORAGE OF COMPONENTS

Our vertical stores enable quick and careful preparation of the components and spare parts intended for assembly and sale.



**TECHNOLOGY**  
**INNOVATION**  
**QUALITY**  
**SAFETY**  
**RELIABILITY**



# TECHNICAL ASSISTANCE

**RAASM** has the most complete range of products for lubrication and the dispensing of fluids. The aim is to always respond fully to the questions of our customers and meet all their needs.





# LUBRICATION

The parts in relative, rotary or linear motion, making up any industrial machine, are producers of friction. The purpose of lubrication is to reduce the friction and consequently the wear of moving parts, significantly decreasing the generation of heat, improving the performance of the machine, and increasing its service life. Lubrication of the moving parts can be obtained by procedures that differ in methodologies, for effectiveness and efficiency.

## MANUAL LUBRICATION

The operator in charge is the only one responsible for the proper lubrication of the moving parts. He decides the quantity of lubricant to be dispensed and the intervals at which the operation is carried out, physically reaching each single lubrication point. Manual lubrication, therefore, depends solely on the operator's diligence and experience. Also, in case of hard-to-reach places the operator is put in uncomfortable or hazardous conditions.

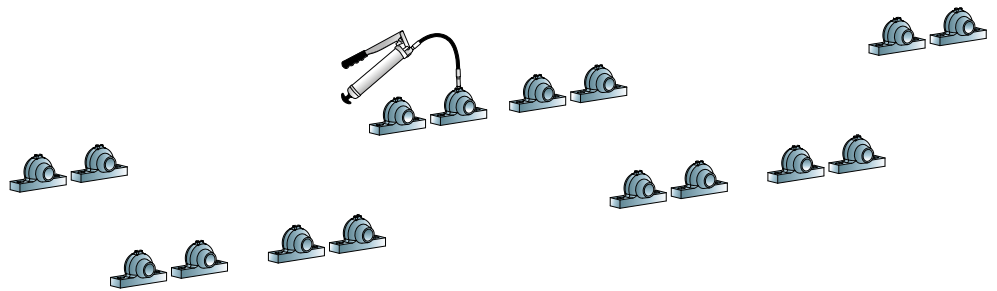

## MANUAL CENTRALIZED LUBRICATION

Compared to the method indicated in the preceding paragraph, with manual centralized lubrication all the machine lubrication points are grouped by means of appropriate piping, thus facilitating the task of the operator, who must intervene on a small number of points, reducing operation times and dosing the quantity of lubricant with greater precision, avoiding uncomfortable or hazardous conditions.

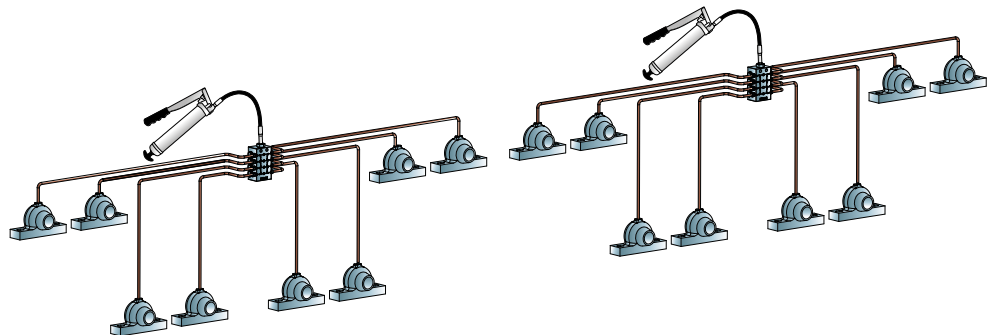

## AUTOMATED CENTRALIZED LUBRICATION

In addition to grouping all the lubrication points in a single point as described above, the operator is completely replaced by a pumping unit and specific control equipment. The main features of this method of lubrication are: correct dosing of lubricant for each single point, the possibility of monitoring the entire system by means of special equipment, programming of dosing through work time/cycles (lubrication) and pauses depending on machine requirements, and monitoring of minimum and maximum oil tank levels.

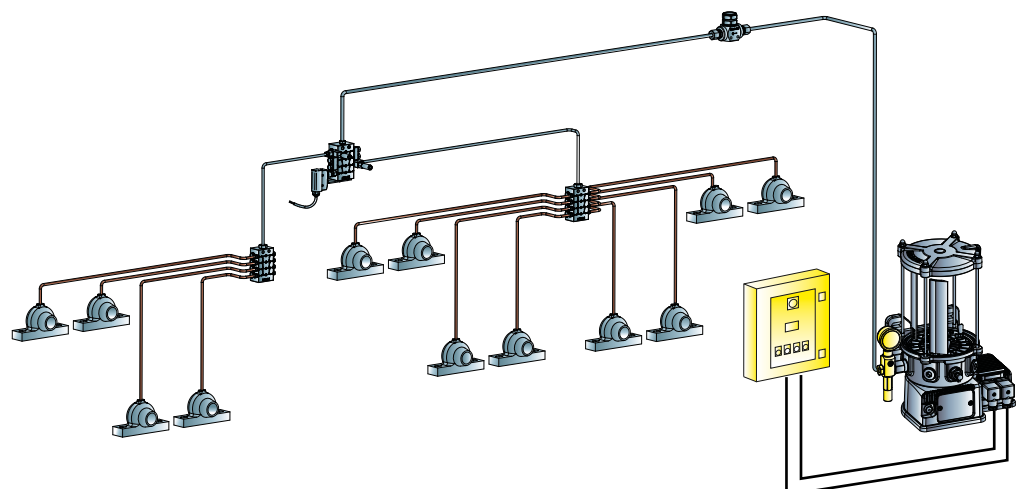





# AUTOMATED CENTRALIZED LUBRICATION

The centralized lubrication systems are designed for the automatic lubrication of moving parts that generate friction. These systems considerably reduce maintenance costs for the machinery on which they are installed, eliminating machine downtimes for lubrication and extending the life of the lubricated components. The automated systems also allow all the points requiring lubrication to be reached; even those not easily reached by an operator.

For example, to better understand the concept, imagine being in your garden and having to water all the flowers and plants. You can choose to do this entirely by hand, using the classic watering can (manual lubrication) or make use of a manually-operated irrigation system (manual centralized lubrication) or add a system that times the delivery of water (automated centralized lubrication).

Given below is a graph comparing the various lubrication conditions, following the methods previously described.

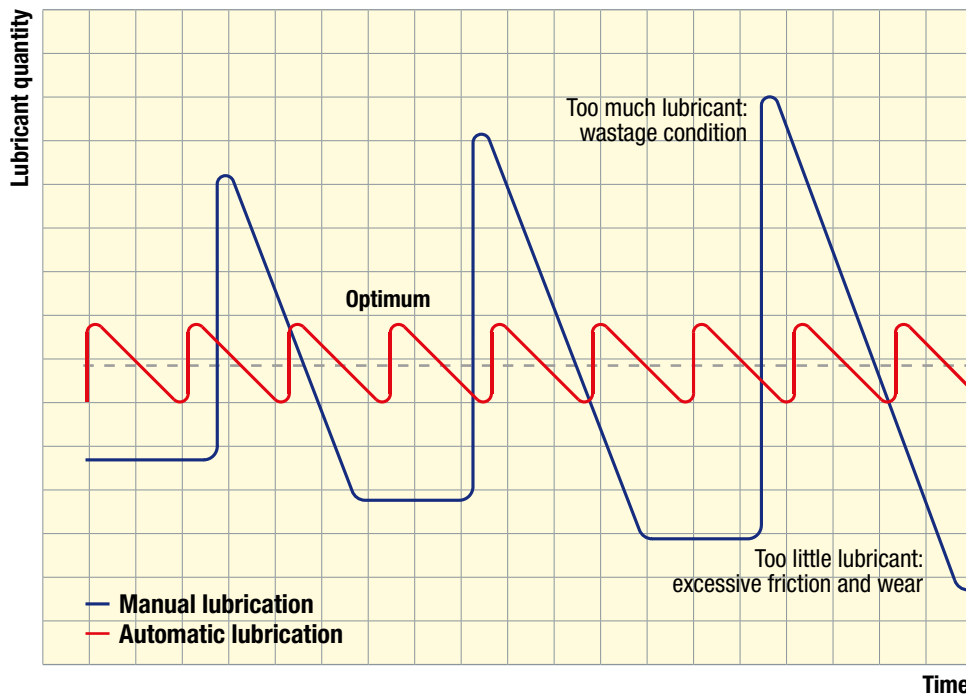

## ADVANTAGES

Automated centralized lubrication offers various advantages compared to manual lubrication:

- Improves the efficiency of the machine, increasing its productivity
- Lengthens the average service life of machinery
- Avoids costly downtimes for insufficient or no lubrication, thus also reducing the costs of repair and spare parts
- Correct dosing avoids unnecessary waste of lubricant, minimising costs and reducing the risk of environmental impact
- Allows hard to access areas to be reached, thereby avoiding potentially dangerous situations for the operator
- Allows the programming of dosing times according to the specific machine requirements, controlling the functionality of the entire system through special control equipment
- Allows the right quantity of lubricant to be adjusted point by point, even in phases after installation
- Facilitates the implementation of the system through the use of additional modular components, thus responding to the changing needs of the end-customer.



# INDUSTRIAL MACHINERY LUBRICATION SYSTEMS

(Reference to international standard ISO 5170)

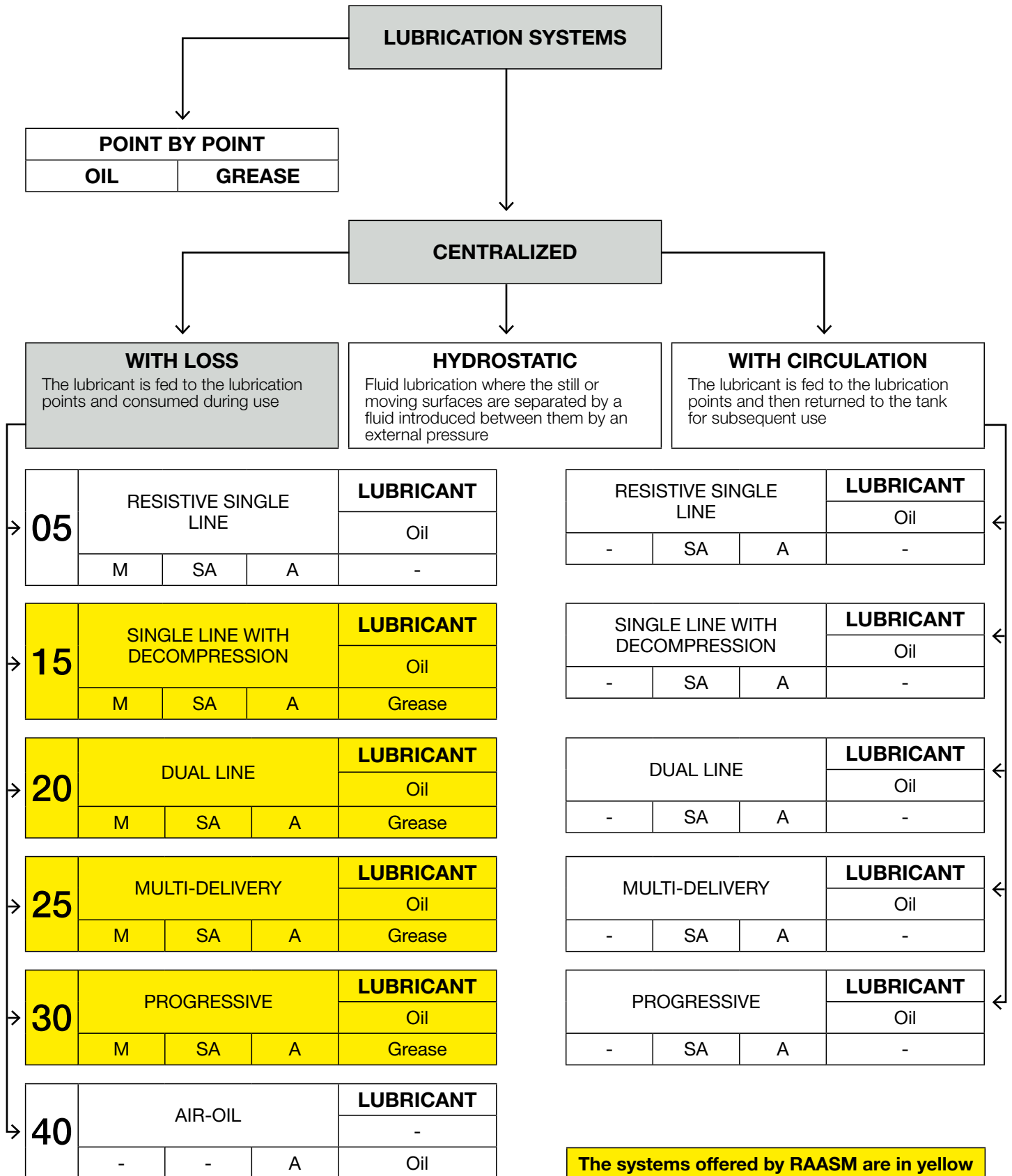

**LEGEND**

<b>M</b>	MANUAL	<b>SA</b>	SEMIAUTOMATIC	<b>A</b>	AUTOMATIC
----------	--------	-----------	---------------	----------	-----------



# AUTOMATED CENTRALIZED LUBRICATION: COMPONENTS

## PUMPING UNIT

It consists of lubricant tank and a pump which can be electric, air-operated or hydraulic.



## VOLUMETRIC DISTRIBUTORS

Hydraulically operated devices, directly connected to the user points, arranged to dispense a predetermined and adjustable quantity of lubricant.



## CONTROL EQUIPMENT

The set of devices (PLC, pressure switches, sensors and level gauges) for programming, monitoring and ensuring proper functioning of the lubrication system.



## FEED LINES

They connect the pumping unit to the volumetric distributors (primary line) and from them to the individual users (secondary line). It consists of rigid pipe in steel, copper or flexible tubing in thermoplastic material, depending on the pressures developed.

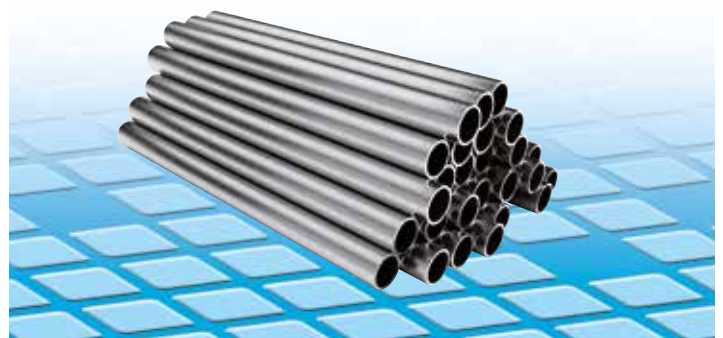



# RAASM CENTRALIZED

## SINGLE LINE WITH DECOMPRESSION 15

It consists of an independent pumping unit which, through a main line, delivers the lubricant (oil or grease) in a predetermined quantity to direct response volumetric dosers (injectors). These volumetric dosing units operate in two phases: in the first phase the pressurization of the system (40-300 bar) allows dispensing of the loaded lubricant. Whereas doser loading (decompression) occurs in the second phase, when the system is not under pressure. Each injector can be adjusted to deliver predetermined quantities of lubricant.

■ Pumping unit

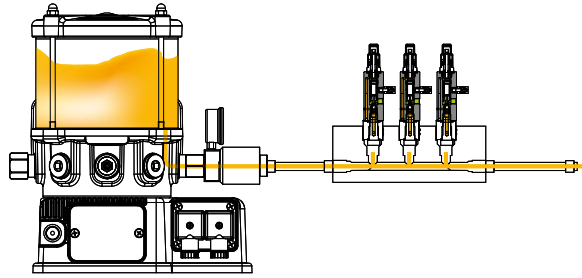

■ Volumetric doser (injector)

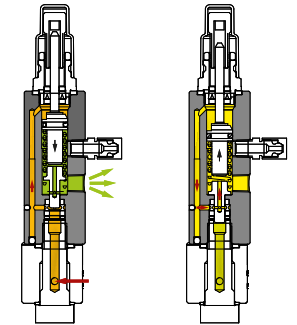

<b>Power supply</b>	*	24 V DC - 230/400 V AC - 50 Hz - 275/480 V AC - 60 Hz - pneumatic
<b>Lubrication session management</b>		By cycles
<b>Controls</b>		One for each critical user
<b>Type of installation</b>		On fixed/movable machinery
<b>Length of system</b>		Medium/long
<b>System architecture</b>		Parallel
<b>Maximum pressure</b>		300 bar
<b>Delivery</b>		Medium/high
<b>Functionality</b>		There are no machine stops/ interruption if an injector sticks

\* **On request:** available different voltages depending on the standard of the various countries of the world.

## DUAL LINE - SYSTEM 20

It is thus defined because lubricant dispensing occurs through two separate lines that are fed alternately by the pumping unit. In turn the two lines feed volumetric distributors connected to them, specially adjustable to dispense predefined quantities of lubricant.

■ Pumping unit

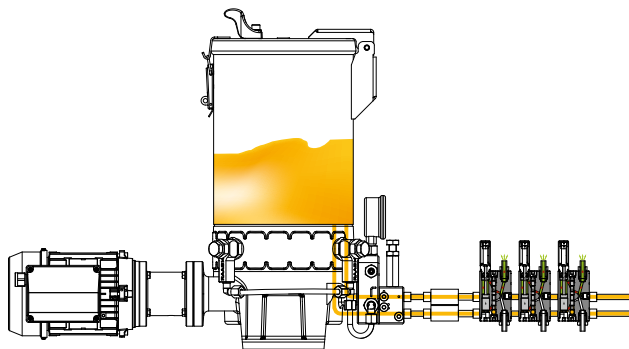

■ Volumetric doser

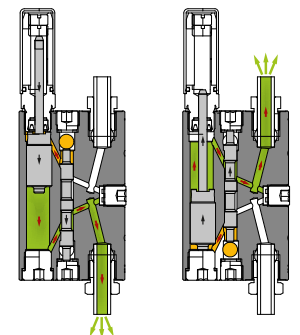

<b>Power supply</b>	*	230/400 V AC - 50 Hz - 275/480 V AC - 60 Hz - pneumatic
<b>Lubrication session management</b>		by cycles
<b>Controls</b>		One for each critical user
<b>Type of installation</b>		On fixed
<b>Length of system</b>		long
<b>System architecture</b>		Parallel
<b>Maximum pressure</b>		400 bar
<b>Delivery</b>		Medium/high
<b>Functionality</b>		There are no machine stops/ interruption if an injector sticks

\* **On request:** available different voltages depending on the standard of the various countries of the world.

# LUBRICATION SYSTEMS

## MULTI-DELIVERY - SYSTEM 25

It consists of a central pumping station allowing the lubrication of a high number of users (up to 16) with oil or grease in predetermined quantities. The pumping unit consists of an electric pump fitted radially with a number of pumping elements which, through the movement of a cam, push the lubricant in succession to the various deliveries, connected to the pipes.

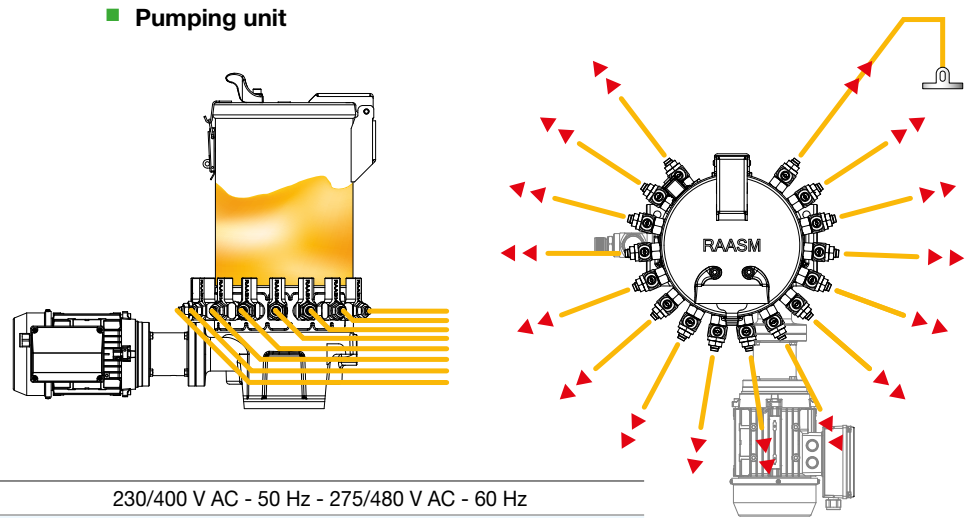

<b>Power supply</b>	230/400 V AC - 50 Hz - 275/480 V AC - 60 Hz
<b>Lubrication session management</b>	Timed
<b>Controls</b>	System maximum pressure
<b>Type of installation</b>	On fixed machinery
<b>Length of system</b>	Medium/short
<b>System architecture</b>	Single pumping element (separate outlets)
<b>Maximum pressure</b>	400 bar
<b>Delivery</b>	Medium
<b>Functionality</b>	There are no machine stops/ interruption if a pumping element jams

\* **On request:** available different voltages depending on the standard of the various countries of the world.

## PROGRESSIVE - SYSTEM 30

It consists of an independent pumping unit that feeds the volumetric distributors equipped with several outlets. The dispensing of lubricant, in a predetermined quantity, occurs through a progressive sequence and not simultaneously as in the previous systems.

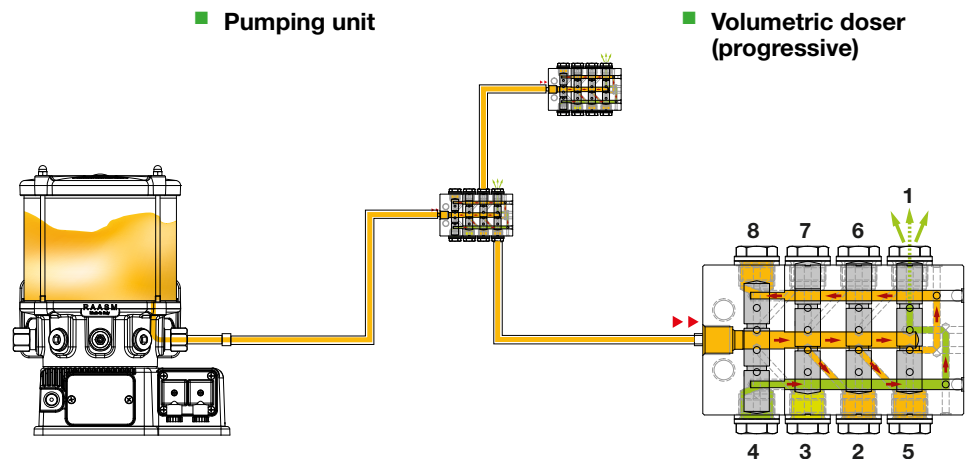

<b>Power supply</b>	12/24 V DC - 230/400 V AC - 50 Hz - 275/480 V AC - 60 Hz - pneumatic
<b>Lubrication session management</b>	Timed/cycle
<b>Controls</b>	A single control is sufficient to check operation of the complete system
<b>Type of installation</b>	On fixed/movable machinery
<b>Length of system</b>	Medium/short
<b>System architecture</b>	In series
<b>Maximum pressure</b>	250 bar
<b>Delivery</b>	Medium/low
<b>Functionality</b>	each dispenser is placed in series with all the others, therefore the malfunction of one causes blocking of all the others

\* **On request:** available different voltages depending on the standard of the various countries of the world.





**ADVANCED FLUID  
MANAGEMENT SOLUTIONS**

# SYSTEM 15





# SYSTEM 15 SINGLE LINE

The single-line decompression lubrication system consists of an independent pump assembly, which distributes the lubricant (oil or grease) to direct-response distributors (injectors) through a main line.

The operation of the system occurs through two phases:  
 1 - Injector loading (the system is not under pressure)  
 2 - Lubricant dispensing (the system is under pressure)  
 Each injector can be adjusted to dispense different quantities of lubricant.

The pump assembly is equipped with a device (discharge valve) which enables rapid decompression of the system immediately after the action of the injectors. The system pressure and the configuration of the injectors in parallel enable the feeding of even very large centralized systems and with a high number of users. Through control of the pressure, verification of operation for each cycle is possible. Lubricating oils and greases up to NLGI 2 can be used. The pumps feeding these systems can be:

- air-operated pumps for standard drums
- air-operated pumps with 10 l. tank
- electric pumps C15 S (radial piston – max. 4)
- electric pumps C15B18 (radial piston – max. 4)

Management and control of the system occurs through the application of modern electrical equipment (PLC, level sensors, microswitches, pressure switches).



## EXAMPLES OF APPLICATION SECTORS

- |                           |                                |
|---------------------------|--------------------------------|
| ■ Bucket wheel excavators | ■ Agriculture                  |
| ■ Cement works            | ■ Conveyor belts               |
| ■ Forestry                | ■ Mining trucks                |
| ■ Quarries                | ■ Excavators with front loader |
| ■ Shiploaders             | ■ Tracked cranes               |

## ADVANTAGES

- Longer life of lubricated components
- Reduced lubricant consumption and operating costs
- Programmed and precise dosing of the lubricant at each point to be lubricated
- System easily extended without the need to be redesigned
- System suitable for particularly demanding environments
- System easy to create (pump plus number of users)
- Injector delivery adjustable directly at installation or after
- There are no lubrication stops/interruptions if an injector sticks
- Injectors with visual control of operation
- Pumping unit offering easy maintenance and very safe operation, working with oil or grease

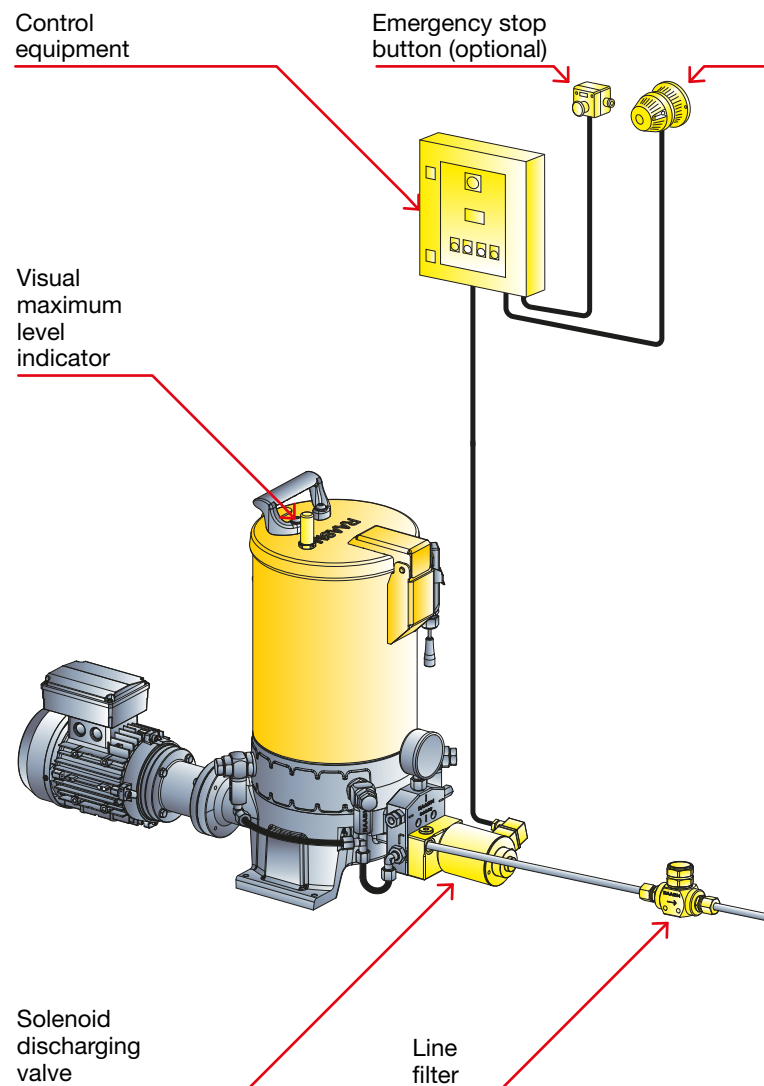





Acoustic and flashing alarm (optional)

Volumetric distributor SLHP-D

Line end pressure switch

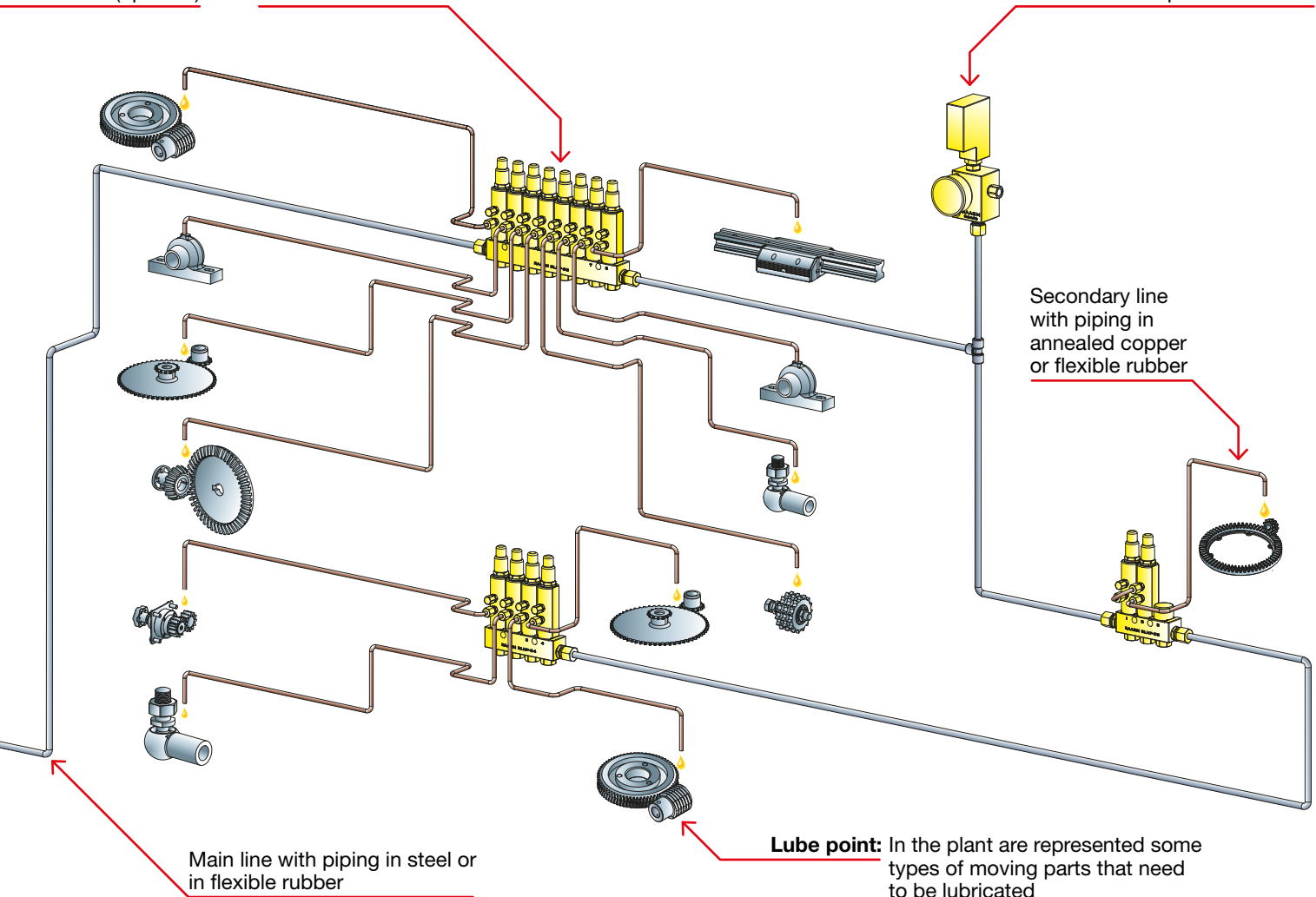





**ADVANCED FLUID  
MANAGEMENT SOLUTIONS**

# SYSTEM 20





# SYSTEM 20 DUAL LINE

The centralized dual-line lubrication systems are normally used in large plants and machines: steel mills, cement works, mines, overhead cranes, shipyard cranes and presses.

The systems are sized in order to be able to reach rather high pressures from 200 to 400 bar. In such systems the length of the piping can easily exceed 70 metres.

## EXAMPLES OF APPLICATION SECTORS

- Bucket wheel excavators
- Cement works
- Forestry
- Quarries
- Shiploaders
- Agriculture
- Conveyor belts
- Mining trucks
- Excavators with front loader
- Tracked cranes

## ADVANTAGES

- Supplies an exact quantity of lubricant from the pumping unit to all the grease points located even at great distances
- The dosing and measuring devices (called volumetric distributors) are managed through two main lines, therefore the lubricant is always under the control of the system at the same time
- The system can be easily extended through the addition of one or more volumetric distributors
- This high pressure system allows the use of particularly narrow pipes, enabling a reduction in the quantity and the deterioration of the residual grease inside the piping, while also reducing installation costs
- Visual check of each volumetric distributor or by means of an appropriate sensor
- If a volumetric distributor does not work, all the other outlets will continue to function normally
- Easy re-calibration of lubricant dosing of each distributor even after installation
- Optimum monitoring and control possibilities using appropriate equipment
- The system keeps the pressure constantly regulated and is able to compensate temperature fluctuations
- The system is able to generate only the necessary pressure required for each lubrication cycle, therefore the pump and other system components of the system are not subjected to pressure variations able to affect their service life

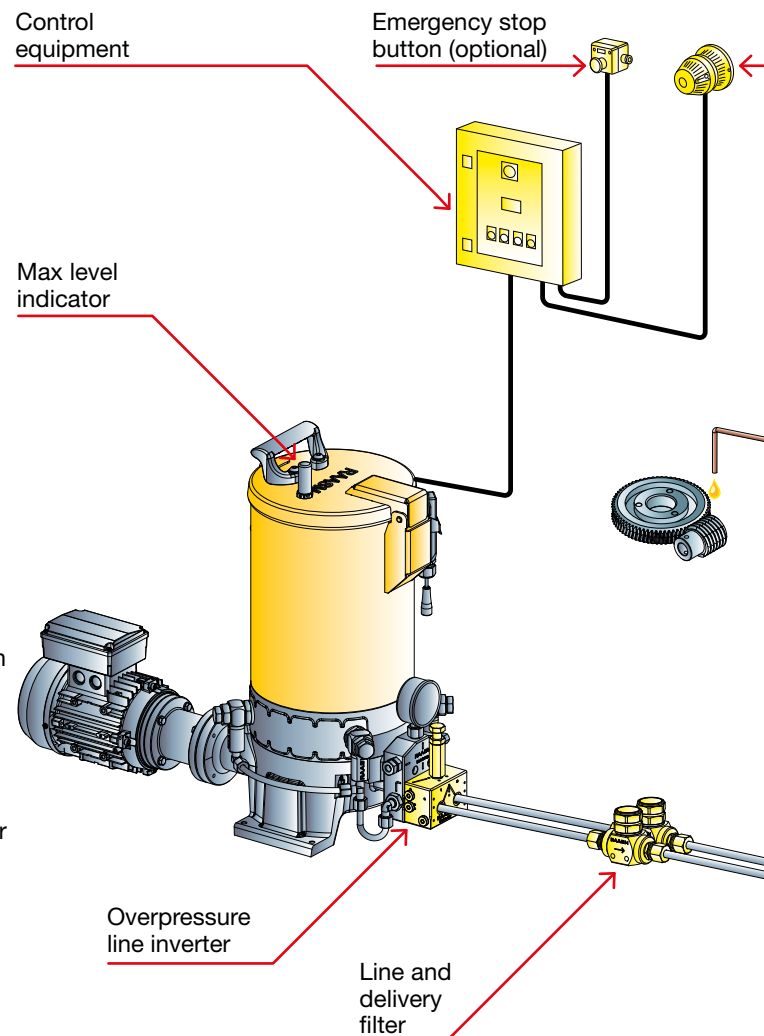



Acoustic and flashing alarm (optional)

Volumetric distributor Series VDL-M

Line end pressure switch

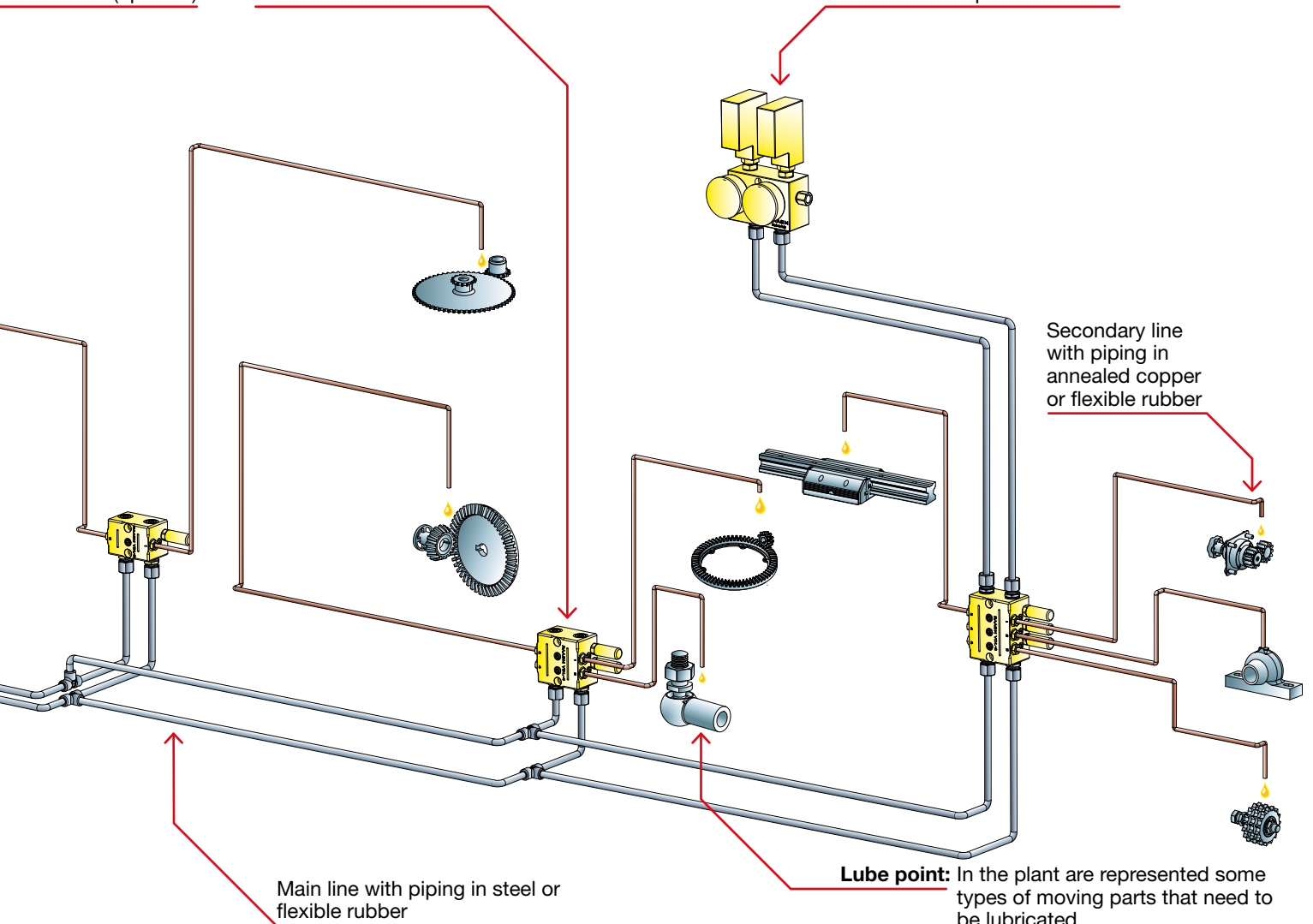

Main line with piping in steel or flexible rubber

**Lube point:** In the plant are represented some types of moving parts that need to be lubricated





**ADVANCED FLUID  
MANAGEMENT SOLUTIONS**

# SYSTEM 25



[www.raasm.com](http://www.raasm.com)



# SYSTEM 25 MULTY DELIVERY

The multi-delivery system enables the lubrication of up to 16 separate users. The central pumping unit consists of an electric pump radially fitted with a series of pumping elements which, through the movement of a cam, push the lubricant in succession to the various deliveries, from which as many feed lines start.

With this system, lubricating oils and greases up to grade NLGI 2 can be used.

The pump assembly can be supplied by a minimum of 1 to a maximum of 16 pumping elements adjustable in delivery. Each pumping element is intended to feed a line, directly to users, volumetric distributors or distributors for spray lubrication.

A maximum pressure switch, connected to an appropriate manifold, enables the control of any sudden changes in pressure in the various lines, possibly due to impurities or foreign matter hindering the flow of lubricant.



## EXAMPLES OF APPLICATION SECTORS

- Machine tools
- Woodworking machines
- Marble working machines
- Construction machinery, concrete mixers, plaster pumps
- Foundry and die casting machines
- Port facilities
- Rubber industry machinery
- Railways, rolling stock
- Mines
- Machines for the steel industry
- Farm machinery
- Water scooping machine

## ADVANTAGES

- Supplies a precise quantity of lubricant from a pumping unit to various lubrication points placed at medium-short distances, through adjustment of the delivery of the pumping elements
- Very safe and easy to maintain pumping unit, working with grease or oil
- Delivery of pumping elements adjustable by means of adjustment screw
- Possibility of using 1 to 16 pumping elements, with their position and orientation as required by the user
- Pumping elements easily to remove and replace
- Possibility of monitoring the system by means of appropriate control and management equipment
- Variable delivery from 4.2 to 140 cm<sup>3</sup>/min (grouping the pumping elements in a single delivery)

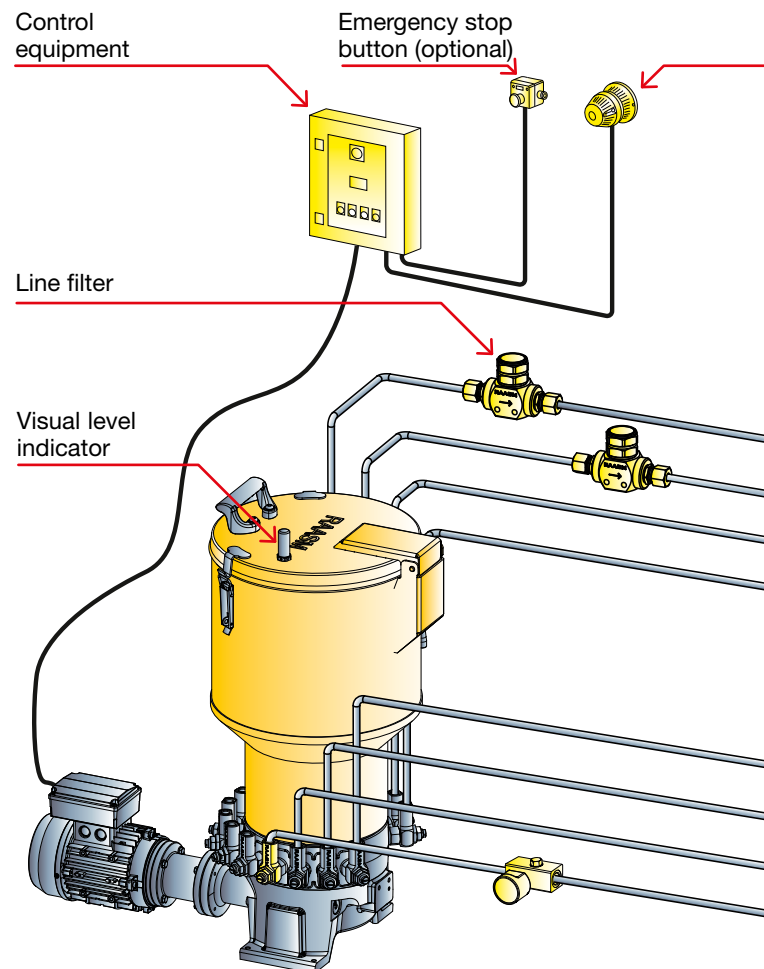



The control manifold with pressure switch, in white galvanized steel controls the delivery pressure of each line. It sends an alarm signal if the measured pressure is higher than a predefined value.

For example, this can occur in case of an obstruction on a pipe or at a user point. It is able to manage up to 8 delivery points. For more than 8 delivery points up to 16 connect in series another manifold.

It is also provided with a discharge union on the bottom of the manifold block. Each inlet is equipped with a one-way valve with F 1/4 "G connection.



The pump C25S is designed to be connected directly to the user points, therefore its pumping elements are used the same way as volumetric dosers.

Each pumping element combines easy maintenance with high operating safety thanks to the two single-acting valves and delivery regulating unit.

The pumping element is mounted radially on the chrome-plated aluminium base and fixed to a ring coupled to eccentric shaft.

This is centrally mounted to the pump from which receives the axial pumping movement. This movement allows the suction and pumping of the lubricant without using springs which could deteriorate or break.



Acoustic and flashing alarm (optional)

Control manifold with pressure switch

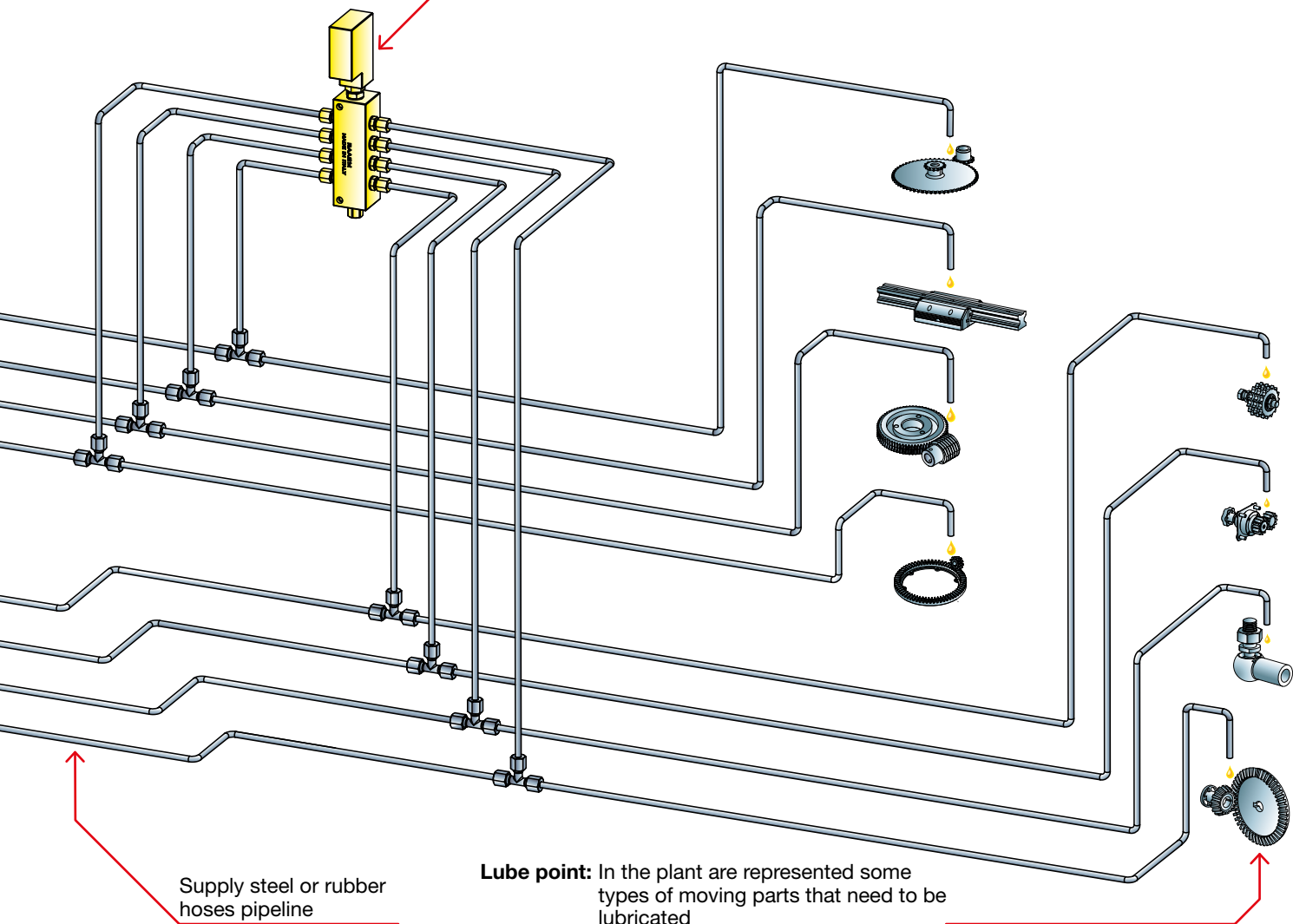

Supply steel or rubber hoses pipeline

**Lube point:** In the plant are represented some types of moving parts that need to be lubricated





**ADVANCED FLUID  
MANAGEMENT SOLUTIONS**

# SYSTEM 30



[www.raasm.com](http://www.raasm.com)



# SYSTEM 30 PROGRESSIVE

The progressive lubrication system consists of a pumping unit connected to volumetric distributors which, through the pumping action of a piston placed inside them, ensure the delivery of a predetermined quantity of lubricant to a corresponding number of users.

This system is defined such, since the action of each piston inside the distributor, which allows the flow of lubricant to pass from one section to another of the distributor, follows a progressive sequence of distribution to the various users.

Each dispenser is placed in series with all the others, therefore malfunctioning of just one causes blocking of all the others. Consequently the control of operation of a single distributor allows the monitoring of the whole system. With this system, lubricating oils and greases up to grade NLGI 2 can be used.

## EXAMPLES OF APPLICATION SECTORS

- Earthmoving
- Trucks - Transport
- Construction machinery, mobile concrete mixers
- Vehicles for garbage collection
- Port facilities
- Rubber industry machinery
- Railways, rolling stock
- Mines
- Machines for the steel industry
- Farm machinery

## ADVANTAGES

- The progressive system ensures that each individual point is properly lubricated through the control of any of the components making up the system
- Possibility of implementing the control for each individual point, when it is all-important to know where a malfunction can occur
- Possibility of installing visual or electric-type controls
- Various distributor models are available for the number of outlets and for deliveries
- Careful choice of materials and treatments, ensuring the long life of all components
- The progressive system is normally used for short work times that include long pause times, hence reduced wear of all parts of the system
- Suitable for medium short systems with a high number of users

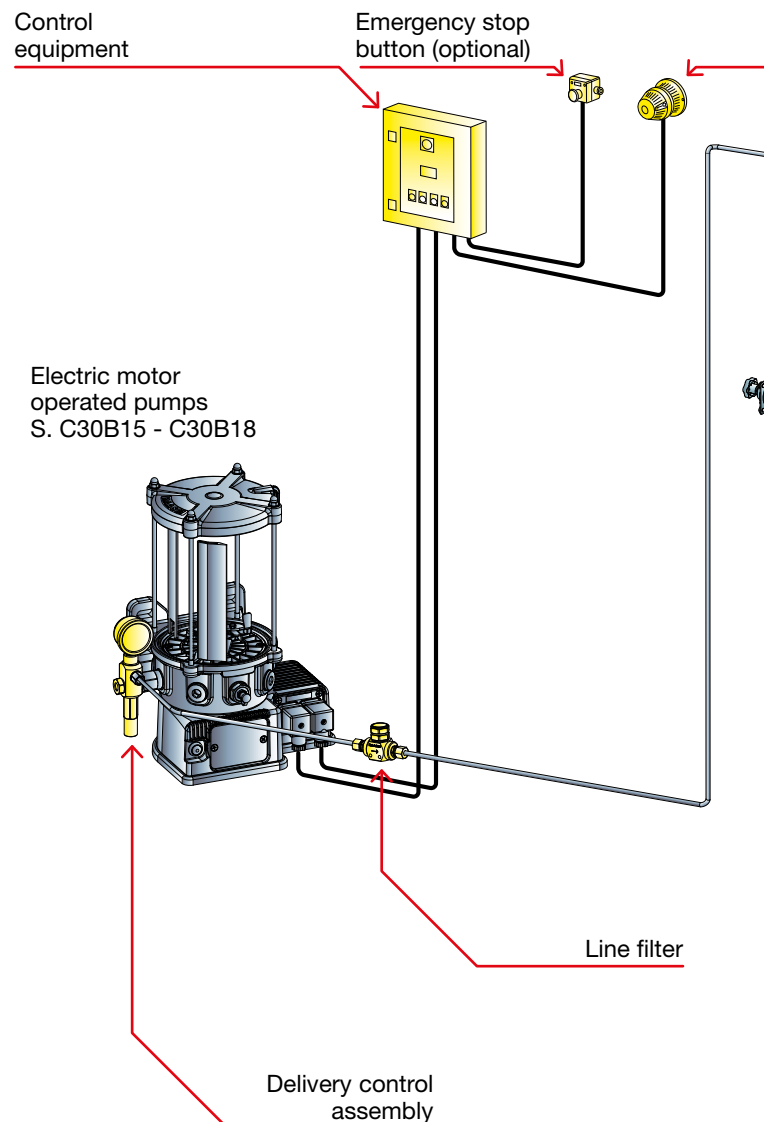



Acoustic and flashing alarm (optional)

Main line with piping in steel or in flexible rubber

Monobloc and modular "Master" divider valves MDV-M and MDV-L

Cycle indicator

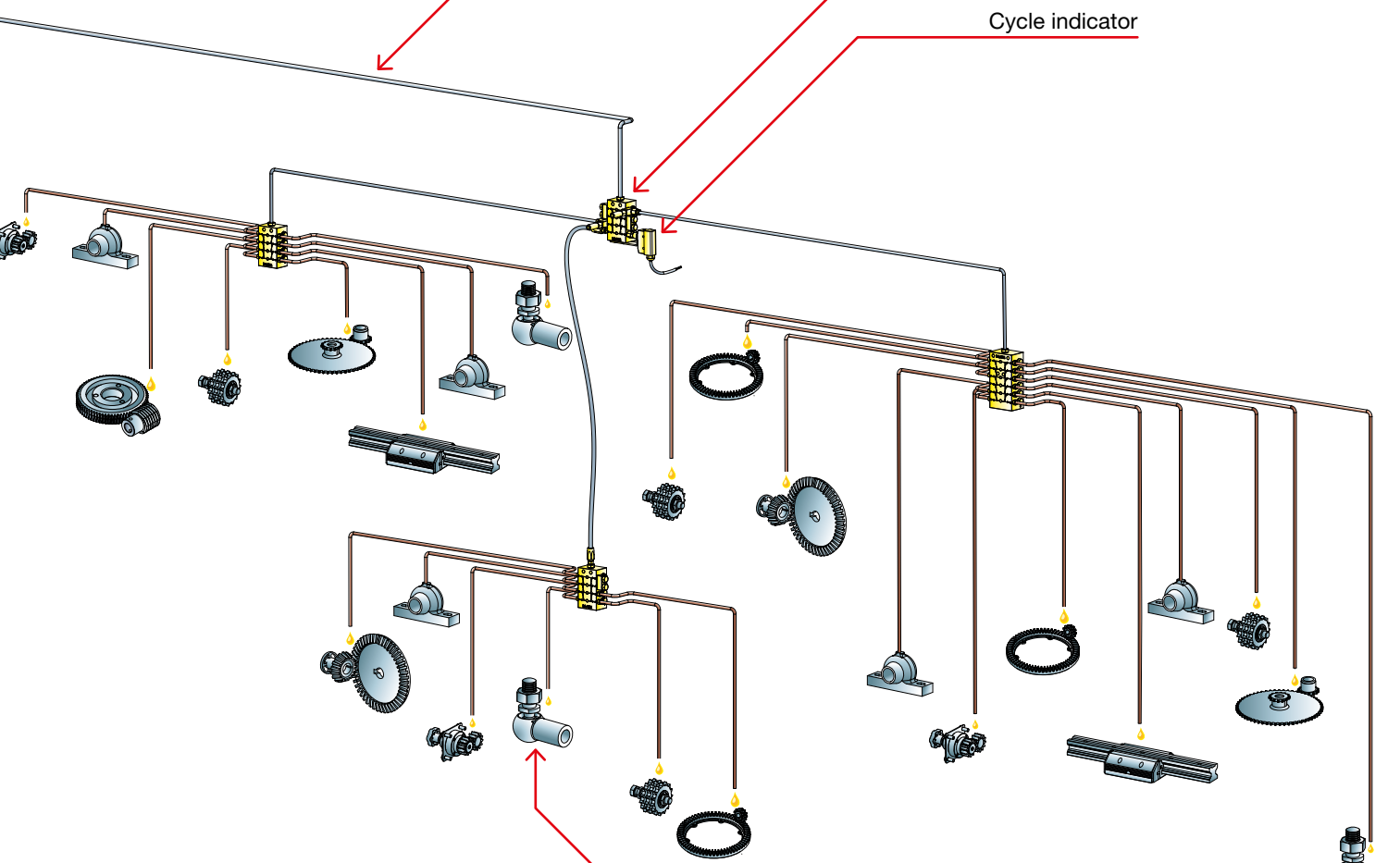

**Lube point:** In the plant are represented some types of moving parts that need to be lubricated











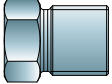
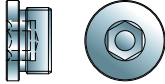
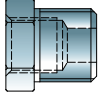

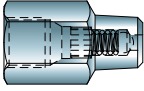

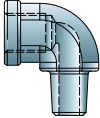
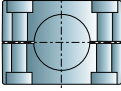
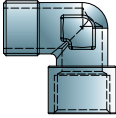
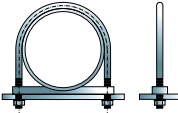

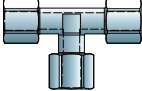

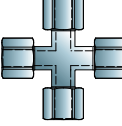
# EXAMPLE ACCESSORIES

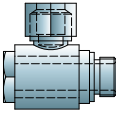
	DESCRIPTION	FITTINGS	DELIVERY/ PRESSURE		DESCRIPTION	FITTINGS	DELIVERY/ PRESSURE
	Overpressure reversing valve	F 1/4" BSP	5500 cm <sup>3</sup> /min		Pumping assembly	F 3/8" BSP	4,2 - 6 - 8,7 cm <sup>3</sup> /min (adjustable pumping element)  30 - 40 - 60 - 80 - 120 cm <sup>3</sup> /min
	Overpressure reversing valve with pressure gauge	F 3/8" BSP	6600 cm <sup>3</sup> /min		Pressure relief valve	F 3/8" BSP	min. 2 bar  max. 8 bar
	Electromechanical reversing valve	F 1/2" BSP	up to 7700 cm <sup>3</sup> /min		Electric discharge valve	24 V DC F 3/8" BSP	max. lubricating pressure 500 bar
	Pressure switch	F 3/8" BSP	from 30 to 400 bar		Control pressure switch unit	F 1/4" BSP	30 - 400 bar
	Filter 30-60-90 micron	F 1/2" BSP	500 bar		Pressure relief and loading valve	On pumping element F 1/4" BSP	100 - 300 bar
	Filter 150-3000 micron						
	Pressure gauge ø 40 mm	1/8" BSP	400 bar		Delivery control valve	F 3/8" BSP	1330 cm <sup>3</sup> /min
	Pressure gauge ø 60 mm	1/4" BSP					
	Pressure gauge ø 63 mm	1/4" BSP	600 bar				
	Pressure gauge ø 100 mm	1/2" BSP					

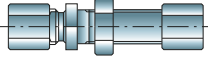
# EXAMPLE FITTING AND TUBES

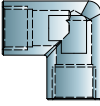
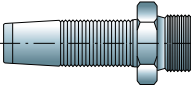
Not provided by Raasm but available in the market

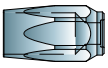
	ABBREV.	DESCRIPTION		ABBREV.	DESCRIPTION
	<b>RB</b>	Bicone union		<b>TTCE</b>	Cylindrical hexagon socket plugs
	<b>RDR</b>	Reduction union		<b>NI</b>	Nipples
	<b>RTVD</b>	Straight and union with valve		<b>GA GR</b>	Seal washers (Aluminium - Copper)
	<b>RTVC</b>	Curved and union with valve		<b>FB FBP</b>	Pipe collars
	<b>REG</b>	Elbow and union		<b>CG</b>	U bolts and couplings
	<b>RID</b>	Straight middle union		<b>TRA</b>	Calibrated copper pipe, annealed
	<b>RIT</b>	Middle "T" union		<b>TAC</b>	Annealed steel pipe, bonderised
	<b>RIC</b>	Middle mcross union		<b>TFL</b>	Flexible thermoplastic tube
	<b>AG</b>	Swivel connectors		<b>TNY</b>	Polyamide tube (Nylon 6)
	<b>RAT</b>	Straight through union		<b>CRL</b>	Smooth recoverable shanks
	<b>GF</b>	90° female elbow		<b>AS</b>	Straight recoverable male connectors
	<b>TCE</b>	Tapered hexagon socket plugs		<b>CG</b>	Recoverable bushings



# SINGLE LINE - SYSTEM 15

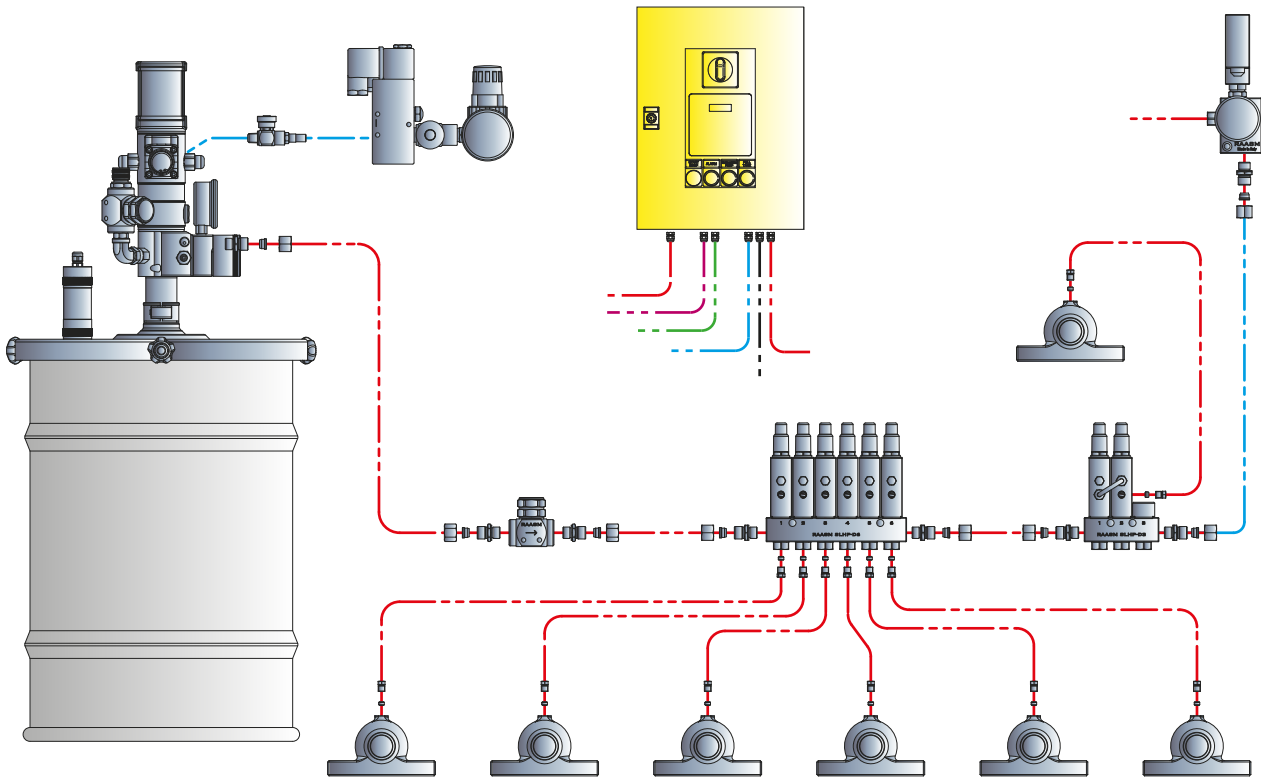

# DUAL LINE - SYSTEM 20

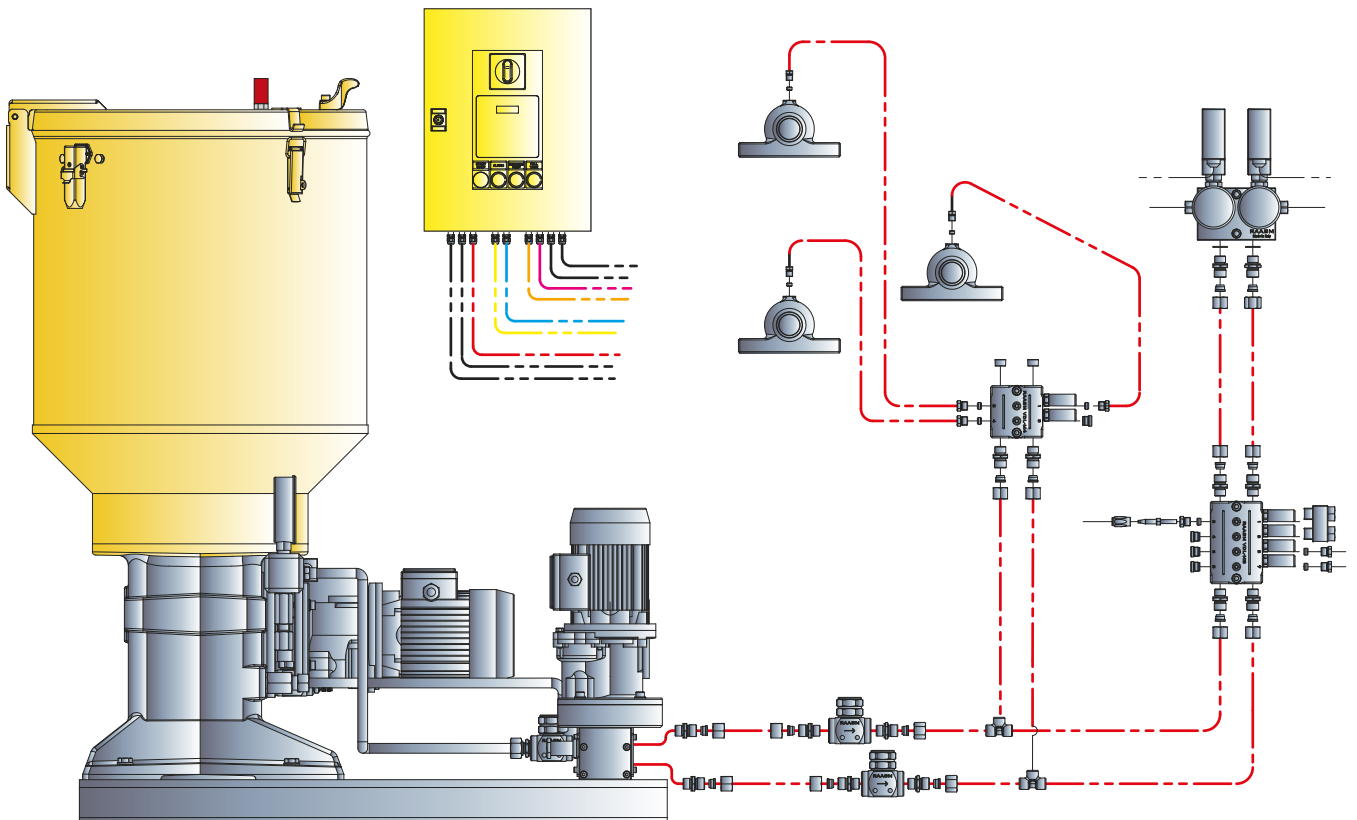



# MULTI-DELIVERY - SYSTEM 25

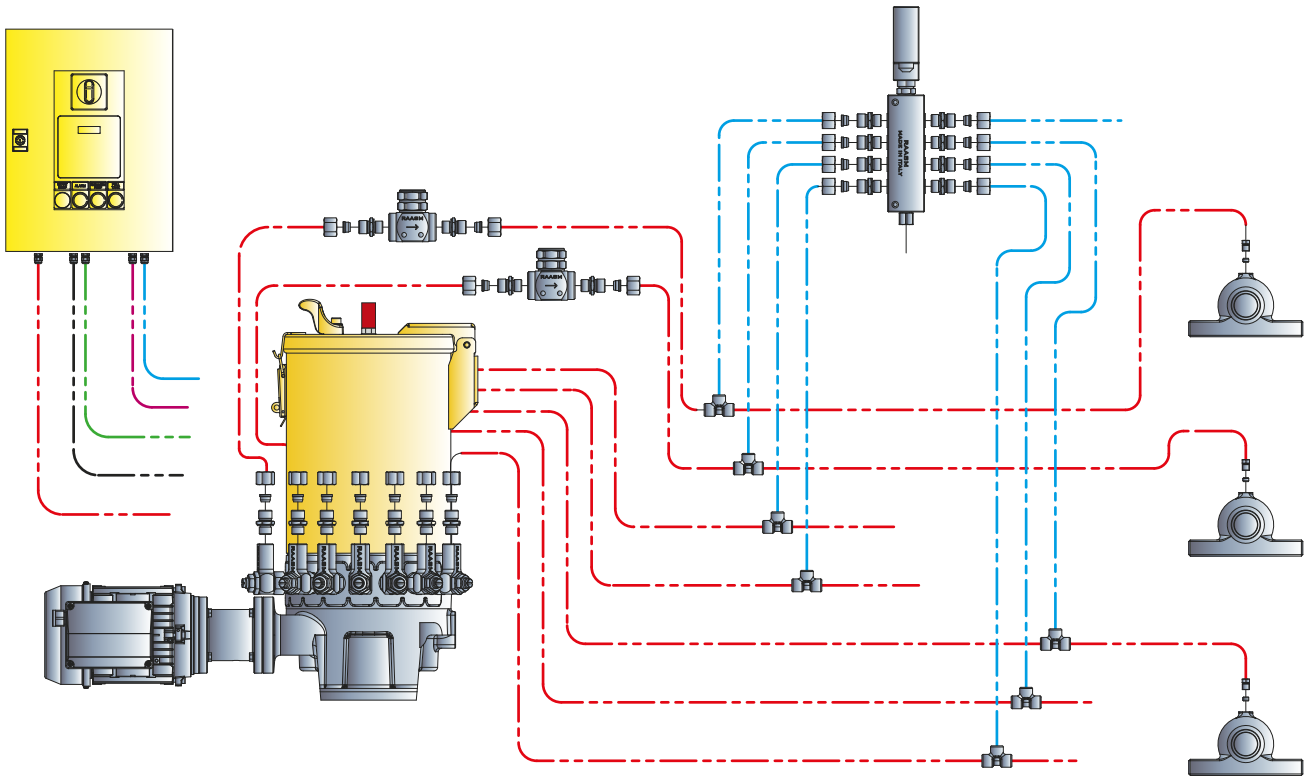

# PROGRESSIVE - SYSTEM 30

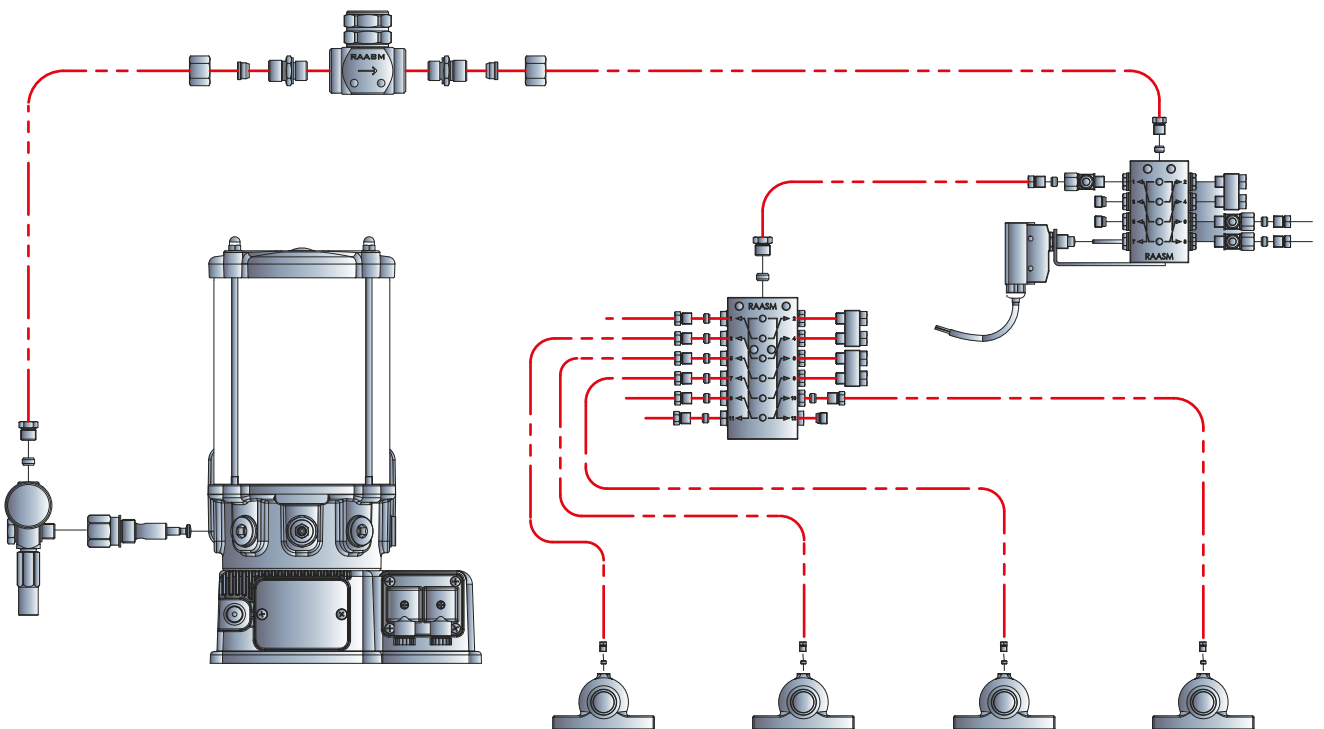



# GLOSSARY

<b>AIR-OIL</b>	A system where lubricant (oil) and air are conveyed together and, through a special device, reach the user points in the form of particles. The flow rate is adjusted by acting on the volume of air and the quantity of lubricant.
<b>CAM</b>	A circular-shaped element, with axis offset with respect to its axis of rotation and generally used to convert continuous rotary motion into reciprocating motion or to generate a vibrating force. (e.g. steam locomotives use cams to turn the rectilinear motion of the pistons into circular motion).
<b>CENTISTOKES (cSt)</b>	The practical unit of measure of kinematic viscosity 100 times smaller than the <b>stokes (St)</b> where $1 \text{ St} = 1 \times 10^{-4} \text{ m}^2/\text{s}$ or $10.000 \text{ St} = 1 \text{ m}^2/\text{s}$ $1 \text{ Cst} = 1 \times 10^{-2} \text{ St}$ or $1 \text{ Cst} = 1 \times 10^{-6} \text{ m}^2/\text{s}$
<b>CYCLE</b>	A lubrication sequence in which all the deliveries connected (distributors - user points) have carried out a lubricant dispensing operation.
<b>CYCLE SENSORS</b>	Electromechanical or magnetic-type devices for detecting the lubrication cycle or phase, by means of an electrical signal to the PLC.
<b>DISTRIBUTORS</b>	These are hydraulically operated devices (volumetric dosers, injectors and progressive), fed by the pumping unit, connected directly to the user points, arranged to deliver a predetermined and adjustable quantity of lubricant.
<b>DUAL LINE</b>	A system with double piping which, alternately in pressure or discharge, feeds distributors (volumetric dosers) that in turn feed user points.
<b>FEED LINES</b>	Usually pipes in different materials and diameters, depending on the pressures developed by the system. They convey lubricant and connect the pumping unit to the distributors (main line) and the distributors to the user points (secondary line).
<b>FRICTION</b>	Is a dissipative force that is exerted between two surfaces in contact with each other at their opposing relative motion. <b>Static friction:</b> if the contact surfaces are at a state of rest. <b>Dynamic friction:</b> if the surfaces are in relative motion.
<b>INJECTOR</b>	A hydraulically operated volumetric distributor, fed by the pumping unit, connected directly to the user points, arranged to deliver a predetermined and adjustable quantity of lubricant. Characteristic of the single line system 15 with decompression (high pressure).
<b>LEVEL SENSORS</b> the	Capacitive or ultrasound devices for signalling the minimum or maximum level of lubricant in the tank to PLC by impulse.
<b>LUBRICANT</b>	A substance in liquid, semi-solid or solid state which, interposed between two surfaces, is suitable for decreasing friction and therefore wear. It creates a very thin layer which allows the separation between two surfaces in contact. Lubricants are divided into: lubricating oils, fluid greases, lubricating greases, very thick greases.
<b>LUBRICATION SESSION</b>	The time interval in which the lubrication operation (adjusted according to a work time or a number of cycles) occurs followed by a pause (pause time).
<b>MAXIMUM PRESSURE SWITCH</b>	A device able to provide an electrical-type signal when the preset pressure is reached.
<b>MULTI-DELIVERY</b>	A system where every user point is fed by a pumping element (with adjustable or fixed delivery) installed directly in the pumping unit.

<b>NLGI</b>	The acronym of National Lubricating Grease Institute, i.e. the body that issued the technical standard for the classification of lubricating greases based on their consistency. The classification comprises a series of consistency intervals, identified by numbers (from 000 to 6). The belonging to a given class depends solely on the penetration value of the grease (expressed in tenths of a millimetre), measured at 25°, with standard cone dropped in the product. (according to standard ASTM D217-97). High penetration values (soft greases) correspond to low NLGI numbers and vice versa.
<b>PLC</b>	The acronym of Programmable Logic Controller, a modular hardware device that executes a programme and processes the digital and analogue signals coming from sensors and directed to the actuators present in an industrial system.
<b>PRESSURE RELIEF VALVE</b>	A pneumatic device (by means of the pump air feed) or electric device (by means of the electromagnetic effect - 24V DC) allowing the pressure inside the system to be discharged and the return of the lubricant to the tank, when a maximum pressure value is reached in the system.
<b>PROGRESSIVE</b>	A system where the quantity of lubricant fed by the pumping unit is supplied to the user points following a progressive distribution sequence.
<b>PROXIMITY</b>	A device also called “proximity sensor” able to detect the presence of objects in the immediate vicinity of the “sensitive side” of the sensor itself, without there being actual physical contact. (e.g. car parking sensors).
<b>PUMPING ELEMENT</b>	A device that allows lubricant to be delivered outside, through the coaxial movement of a piston inside the pumping body. The delivery of lubricant can be adjustable or fixed.
<b>PUMPING UNIT</b>	Usually an electric, air-operated or hydraulically-operated pump with tank, for distributing lubricant through feed lines to the various distributors.
<b>RADIAL PUMPING ELEMENT</b>	A pumping element fixed along the circumference of the pump body. This position allows the pumping of lubricant, thanks to the coupling on the ring of the eccentric shaft. Characteristic of electric pumps C20S - C30S - C25S.
<b>RESISTIVE</b>	A system where the quantity of lubricant (oil) fed by the pumping unit is supplied to the user points by means of adjustable flow control valves which determine the quantity of lubricant to be dispensed.
<b>REVERSING VALVE</b>	A hydraulically operated or electric motor operated device used in the Double Line system. Its task is to reverse the lubricant feed from line 1 to line 2 (and vice versa) once a predetermined maximum pressure value is reached.
<b>SINGLE LINE</b>	A system in which a single pipe feeds distributors that in turn feed user points.
<b>USER POINTS</b>	The places of a machine to be lubricated in order to reduce the friction generated during operation.
<b>VISCOSITY</b>	Commonly defined as the resistance met by the mass of fluid (liquid or gas) flowing freely in a duct. This impediment depends on the cohesion forces existing between the molecules of the fluid, which exert a braking action on the free sliding of the layers of the substance on each other. The viscosity depends on the type of fluid and the temperature; in fact, in liquids it decreases as the temperature increases, but increases in gases. There are various viscosity classifications for lubricating oils, with respective comparison tables (e.g. from cSt to ISO VG - AGMA - SAE - SUS).



**ADVANCED FLUID  
MANAGEMENT SOLUTIONS**

RAASM has a wide range of  
lubrication equipments an solutions.  
Have a look at them in our  
catalogue 219.

[www.raasm.com](http://www.raasm.com)





**RAASM** products  
are present worldwide through a network of  
qualified dealers.

# GENERAL SALES CONDITIONS

## FOR FOREIGN MARKETS



The following general sales conditions regulate the sale of goods and services by the company RAASM S.p.A. for customers residing outside the territory of the Italian State.

### **P/N 1 GOODS DELIVERY TERMS**

The goods are delivered ex works RAASM S.p.A. The subsequent transport/shipment must occur by, in the name and at the expense of the purchasing customer, even by means of a carrier appointed and designated by the same. All risks arising from loading, subsequent custody and transport are borne entirely by the purchasing customer.

### **P/N 2 MINIMUM ORDERS**

Each order cannot be for less than € 1,500.00, net of fees, taxes, customs duties, discounts and rebates and any other charges not included in the price of the goods. If, at the option of RAASM S.p.A., orders for lower amounts are accepted, an extra charge of € 155,00 shall be applied for order management administrative expenses.

### **P/N 3 ACCESSORIES**

All the accessories given in the price list (plugs, oil bar taps, oil guns, grease guns, probes, protection caps, clutches, swivelling supports, etc.) are supplied exclusively for fitting to or combining with the items RAASM S.p.A. produces

### **P/N 4 COMPLAINTS**

Any defects immediately noticed after a brief inspection of the goods (damage, shortages or different product from that ordered) must be notified in writing to our company within 8 (eight) days of receipt the goods. Any defects in the product noticeable only during its use must be notified in writing to RAASM S.p.A. within 8 (eight) days of being detected. Any returns of goods must be authorized in advance by RAASM S.p.A. and freight charges are at the customer's expenses.

### **P/N 5 DELIVERY TIMES/TERMS**

Delivery times and dates are only approximate and are subject to change. Any delays in delivery do not entitle the customer to cancel the order or claim compensation for damages caused by delay of delivery. Delivery times for urgent orders must be agreed directly with RAASM S.p.A. RAASM S.p.A. has the right not to carry out the order and/or totally or partially carry it out, without this giving rise to reimbursement or claims for compensation for damage.

### **P/N 6 PACKS AND PACKAGING**

Packaging costs are included in the price, except for special packing, which shall be charged at cost.

### **P/N 7 PRICES**

The current Price list cancels and replaces the previous price list. In the event of changes to our price list and/or individual items, the goods shall be forwarded at the price in force on the day of the order confirmation. The price list and/or the prices of individual items can be changed even without notice, according to the changes in market conditions or technical innovations/modifications made to the product. The prices are understood to be ex works RAASM S.p.A.

### **P/N 8 PAYMENTS**

Payments must be made exclusively to RAASM S.p.A. at the agreed conditions. Under no circumstances will deductions or roundings be accepted. In case of late payment with respect to the agreed conditions, RAASM S.p.A. reserves the right to charge interest at the current rate, effective from the day after that agreed for payment, plus any additional expenses. Discounts conditional on the payment term and already credited shall be recharged.

### **P/N 9 WARRANTY**

RAASM S.p.A. provides each product with the communication of particular instructions for the installation, use and maintenance requirements and the need to carry out possible checks on the product. All the technical information and data mentioned in the catalogue and in the price-list in force are not binding and can be changed without prior notice for the purpose of improving the quality of the products. All products manufactured by RAASM S.p.A. are guaranteed for a period of 5 (five) years from the date of delivery to the first user. The user must keep and show the sales invoice - or an equivalent document - together with the item's serial number in order to make a claim under the RAASM S.p.A. guarantee. The 5 (five) year guarantee does not apply to components which are subject to normal wear and tear (such as gaskets, diaphragms, O-rings, hoses, etc.), electronic components and items that are sold but not manufactured by RAASM S.p.A. (marked with a red asterisk in the current product catalogue) which are guaranteed for 1 (one) year from the date of delivery to the first user.

1 (one) year warranty is valid also for the following products:

- digital litre counters and FCS system;
- cable reels;
- electric, pneumatic or hydraulic motor supplied with our industrial hose reels S. 600 and 700.

Incorrect installation, use or maintenance of the product shall void the warranty. Upon written notice, the articles must be returned free to our Factory for checking and acceptance. In any case, the guarantee expires in the 10th year from the date of manufacture (indicated by the serial number), if the stated expiry takes place before the expiration terms indicated above (1 or 5 years from delivery to the first user).

The manufacturer declines any responsibility for possible inaccuracies contained in this catalogue, due to printing or transcription errors. The manufacturer reserves the right to make any changes or improvements of a functional, technical or aesthetic nature without prior notice.

**The publication and the reprint of this price list is forbidden.**

# RAASM

## **P/N 10 RESPONSIBILITY**

RAASM S.p.A. is exempt from any responsibility and liability for accidents that may occur to persons and property, as a result of or during the use of the equipment, due to or depending on the same whenever the products have been damaged during transport, tampered with or modified, or improperly used, or stored, installed, protected and preserved without complying with the instructions of RAASM S.p.A. as given in the installation, use and maintenance instruction manuals for each product. RAASM S.p.A. is liable for the value for the supplied product and cannot be held responsible in any way for other possible costs or additional costs that the customer may bear.

## **P/N 11 CONFIDENTIALITY**

Information not in the public domain that is exchanged in the execution of the contract is subject to the obligation of confidentiality, secrecy and security; said information is covered as an industrial secret and is of a confidential and reserved nature and may not be disseminated to third parties; its use is permitted exclusively and strictly to execute the supply contract.

## **P/N 12 INTELLECTUAL PROPERTY RIGHTS**

The RAASM trademark, and likewise the name RAASM, RAASM S.p.A., the logo and the other distinctive signs are internationally registered trademarks, and RAASM S.p.A. does not authorise their use and application under any circumstances. Without prior written consent from RAASM S.p.A., the content of catalogues, price lists, instruction manuals and similar, including content on the website may not be reproduced, either entirely or partially, nor may it be transferred by electronic or traditional means, nor may it be modified or utilised by any means and for any purpose. All rights are held by RAASM S.p.A. The customer acknowledges that RAASM S.p.A. holds exclusive ownership of all the parts, images, photographs and signs not in common usage, the content in the catalogues, price lists, instruction manuals and similar and/or present on the website [www.raasm.com](http://www.raasm.com) and/or other channels and/or social networks used by RAASM S.p.A. for their informational and marketing campaigns pursuant to Copyright Law and the Industrial Property Code.

## **P/N 13 INFORMATION ON THE PROCESSING OF DATA PURSUANT TO ITALIAN LEGISLATIVE DECREE 196/2003**

In accordance with article 13 of Italian Legislative Decree 196/2003 - Personal Data Protection Code - you are hereby advised that the processing of the personal data, provided with the purchase of goods or services and/or the supply of goods or services is solely for the purposes of carrying out the contract-based obligations and to comply with the specific requests from customers/ suppliers, as well as adhering to legislative obligations, in particular accounting and tax obligations or to respect orders issued by public authorities or to exercise a right in court. The data shall also be used for commercial statistics for corporate use and to obtain commercial information on our products and services if expressly authorised by the applicant. The processing of data shall be done using hard-copy and computerised procedures, in the manner and within the limits necessary to achieve the aforementioned purposes. Data may be communicated and processed by other companies in the Group for the same specified purposes, and may be made known to employees of our company, consultants and other suppliers, always and exclusively within the limits of the aforementioned purposes. The provision of data is mandatory for the correct execution of the contract and pre-contract based obligations, and failure to do so could result in it being impossible to fully comply with contractual obligations, and make it impossible to provide updates on the new products and services offered by our company. Data shall be processed for the duration of the contract relationship in place and subsequently to fulfil any legal formalities.

## **P/N 14 RIGHTS OF DATA SUBJECTS**

The information is aimed at defining the limits and methods for the processing of data, based on which individual customers and/or suppliers may freely authorise the collection and subsequent use of data. Data subjects are entitled to the rights pursuant to article 7 of the aforementioned Code and in particular, the right to access their personal data, ask for the amendment, update and cancellation thereof, if incomplete, incorrect or collected in violation of the law, and may object to the processing for legitimate reasons, addressing requests in this regard to RAASM S.p.A. Pursuant to the same article the data subject also has the right to request the complete and updated list of the Data Supervisors, and to ask for the cancellation, transformation into anonymous form or blocking of data processed in violation of the law, and to oppose in any case, for legitimate reasons, the processing thereof. To exercise these rights, and in the case of problems or any requests for clarification regarding what has been explained herein, kindly address these to RAASM S.p.A. - Via Marangoni, 33, Cassola (VI) - Italy or to the following email address: [info@raasm.com](mailto:info@raasm.com).

## **P/N 15 DATA CONTROLLER**

The Data Controller is RAASM S.p.A. with registered office at Via Marangoni 33, Cassola (VI) – Italy, and this is where the data processing shall take place.

## **P/N 16 COMPETENT LAW COURT**

Any disputes shall be settled by the Law Court of Vicenza, Italy.

The company RAASM S.p.A. holds the exclusive Intellectual Property rights on the RAASM trademark and all rights to its use and reproduction are reserved. The RAASM trademark is a registered trademark and is protected at an international level. No part of the RAASM trademark and its logo may be utilized, copied and/or used in any form, time and space, even by means of improper alterations.

The Intellectual Property rights on the images published in this catalogue are owned exclusively by RAASM S.p.A. and any unauthorized reproduction is prohibited.

Any use in general of the assets protected by the Intellectual Property rights of RAASM S.p.A. is prohibited and is subject to the prior written permission of RAASM S.p.A.





## THREE WORDS TO DESCRIBE RAASM

### ■ Technology

The starting points for the entire production cycle consist of planning and research for new solutions, which will become cutting-edge **high quality products entirely made in Italy.**



### ■ Quality

Quality has always been a main priority in the manufacture of RAASM products. In order to obtain this, also many rigorous and progressive tests are indispensable.



### ■ Functionality

RAASM has the most complete range of products for lubrication and the dispensing of fluids. The aim is to always adequately address and meet the needs of each individual customer.



Authorized dealer



Company with an ISO 9001:2015 certified quality management system

RAASM S.p.A. - 36022 S. ZENO DI CASSOLA (VI)  
Via Marangoni, 33 - ITALY

Export department Tel. +39 0424 571130 - Fax +39 0424 571135  
Technical department Tel. +39 0424 571150 - Fax +39 0424 571155

info@raasm.com - www.raasm.com

